

AC/DC Desktop Adapter



Features

- 100-240VAC Universal Input
- LED Indicator
- LPS Compliance
- Protections:
 - Short circuit / Over voltage / Over current
 - Over Temperature (optional)
- Energy Efficiency Level VI or CoC Tier II
- No Load Power Consumption
 - Less than 50W: $\leq 0.1W$ (VI), $\leq 0.075W$ (Tier II)
 - More than (includes) 50W: $\leq 0.21W$ (VI), $\leq 0.15W$ (Tier II)
- MTBF > 100,000 hours

EA1068 X Y - vv PP

- X:** AC inlet: 1. C14 2. C8 3. C6 6. C18
- Y:** Output range
- vv:** Specified output voltage, i.e. 12 is 12VDC
- PP:** DC plug type, i.e. Code 01 for 5.5x2.1mm or other options (refer to the appendix page)

MODEL No.	MAX. OUTPUT POWER (W)	OUTPUT VOLTAGE (Vo)	MIN. LOAD (Io)	MAX. LOAD (Io)	LOAD REGULATION	LINE REGULATION	RIPPLE & NOISE
EA1068xA	25W	5V~9V	0A	5.0A	± 5%	± 1%	180mV
EA1068xB	40W	12V~16V	0A	3.33A	± 5%	± 1%	240mV
EA1068xC	40W	18V~24V	0A	2.10A	± 5%	± 1%	360mV
EA1068xD	40W	32V~42V	0A	1.25A	± 5%	± 1%	630mV
EA1068xE	40W	44V~56V	0A	0.90A	± 5%	± 1%	840mV
EA1068xF	30W	5V~9V	0A	6.0A	± 5%	± 1%	180mV
EA1068xG	50W	12V~16V	0A	4.16A	± 5%	± 1%	240mV
EA1068xH	50W	18V~24V	0A	2.63A	± 5%	± 1%	360mV
EA1068xJ	50W	32V~42V	0A	1.56A	± 5%	± 1%	630mV
EA1068xK	50W	44V~56V	0A	1.13A	± 5%	± 1%	840mV
EA1068xW	40W	5V~9V	0A	8.0A	± 5%	± 1%	180mV
EA1068xM	35W	5V~9V	0A	7.0A	± 5%	± 1%	180mV
EA1068xN	60W	12V~16V	0A	5.0A	± 5%	± 1%	240mV
EA1068xP	60W	18V~24V	0A	3.15A	± 5%	± 1%	360mV
EA1068xQ	60W	32V~42V	0A	1.87A	± 5%	± 1%	630mV
EA1068xR	60W	44V~56V	0A	1.36A	± 5%	± 1%	840mV
EA1068xY	65W	12V~16V	0A	5.42A	± 5%	± 1%	240mV
EA1068xS	45W	5V~9V	0A	9.0A	± 5%	± 1%	180mV
EA1068xU	72W	12V~16V	0A	6.0A	± 5%	± 1%	240mV
EA1068xV	72W	18V~24V	0A	3.78A	± 5%	± 1%	360mV
EA1068xL	72W	32V~42V	0A	2.25A	± 5%	± 1%	630mV
EA1068xT	72W	44V~56V	0A	1.63A	± 5%	± 1%	840mV

NOTE:

- 1 : Ripple & Noise is measured by using 20MHz bandwidth limited oscilloscope and terminated each output with a 0.1uF ceramic capacitor & parallel with 47uF aluminum capacitor at full load and nominal line.
- 2 : Line regulation is defined by changing $\pm 10\%$ of input voltage from nominal line at rated load.
- 3 : Max. Power (W) $\geq V_o \times I_o$

Electrical Specification

INPUT

- Input Range: 100 to 240 VAC
- Frequency: 50 to 60Hz
- Input Current: $\leq 2.0A$
- Inrush Current: 80A/100VAC 120A/230VAC
- Hold Up Time: $\geq 8.3ms$
- Turn On Time: $\leq 3s$

OUTPUT

- Short Circuit Protection: Auto Recovery
- Over Voltage Protection: Latch-off / Auto Recovery
- Over Current Protection: Auto Recovery
- Over Temperature Protection: Optional

ENVIRONMENT

- Operating Temperature: 0 to 40°C
- Storage Temperature: -20 to 85°C
- Operating Humidity: 10% to 90%
- Storage Humidity: 5% to 95%

SAFETY

- Certified for whole series: UL/cUL 62368-1, TUV EN 62368-1, CB IEC 62368-1, FCC, CE
- Certified for assigned models: CCC, BSMI, PSE, RCM, KC, CU, PSB, NRCAN, Argentina

Mechanical Specification

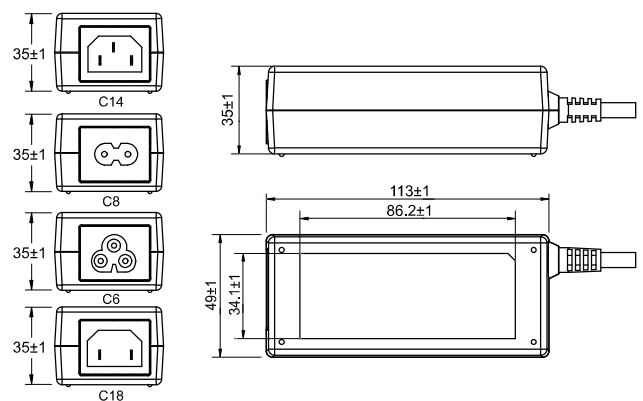

- Case Size: 113L x 49W x 35H (mm)
- AC Inlet: C14, C8, C6, C18
- Weight: 300g