



Controller Model: **Allen-Bradley PLC-5 Family**

Maple OIT Model: **MAP460D, OIT3600B**

Communication Type: **RS-232 with DB25 connector at PLC**

Use the wiring diagram and illustration to assemble a communication cable for use with an Allen-Bradley PLC-5 Family PLC. Maple System's products use the DF1 protocol to communicate with this PLC. This cable is for communication directly from the DF1 port.

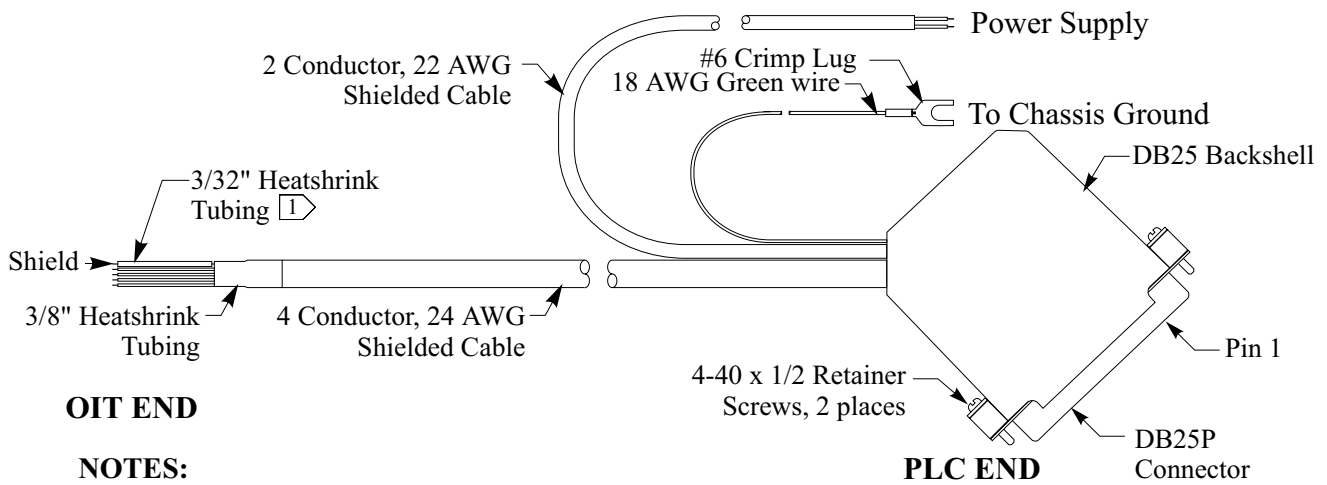

OIT END

NOTES:

- 1 Install heatshrink on shield (bare wire) to avoid shorting to components.
- 2 Twist together 18 AWG green wire and shield wire. Solder wires and insulate with heatshrink tubing to avoid shorting.

