

C A B L E A S S E M B L Y I N S T R U C T I O N

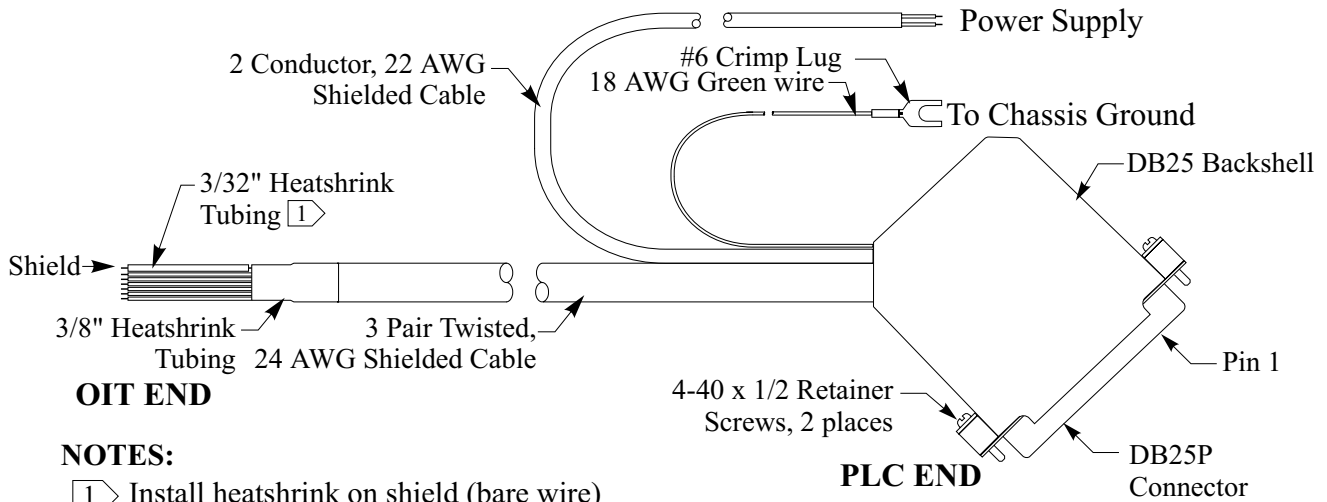

Controller Model: **Mitsubishi FX/FX2c**
 Maple OIT Model: **MAP460D, OIT3600B**
 Communication Type: **RS-422 with DB25 connector at PLC**

Use the wiring diagram and illustration to assemble a communication cable for use with a Mitsubishi FX/FX2c PLC.



OIT END

NOTES:

- 1 Install heatshrink on shield (bare wire) to avoid shorting to components.
- 2 Twist together 18 AWG green wire and shield wire. Solder wires and insulate with heatshrink tubing to avoid shorting.

