

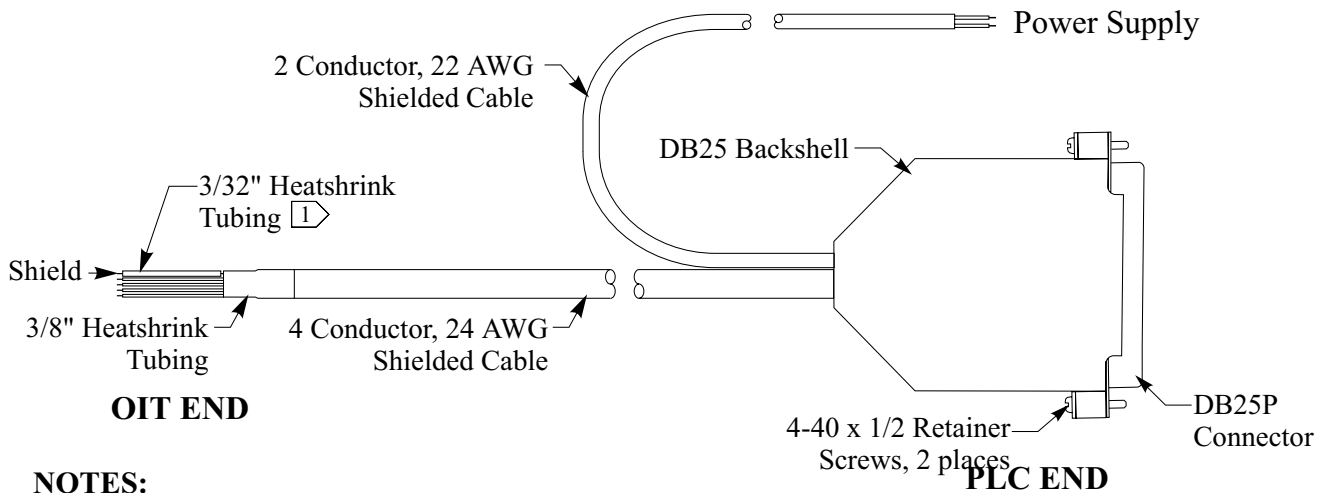

Controller Model: **GE Fanuc 90-30 CMM311 Port 1**  
 Maple OIT Model: **MAP460D, OIT3600B**  
 Communication Type: **RS-232 with DB25 connector at PLC**

Use the wiring diagram and illustration to assemble a communication cable for use with a GE Fanuc 90-30 PLC (CMM311 Port 1).



**NOTES:**

- 1 Install heatshrink on shield (bare wire) to avoid shorting to components.

