

C A B L E A S S E M B L Y I N S T R U C T I O N

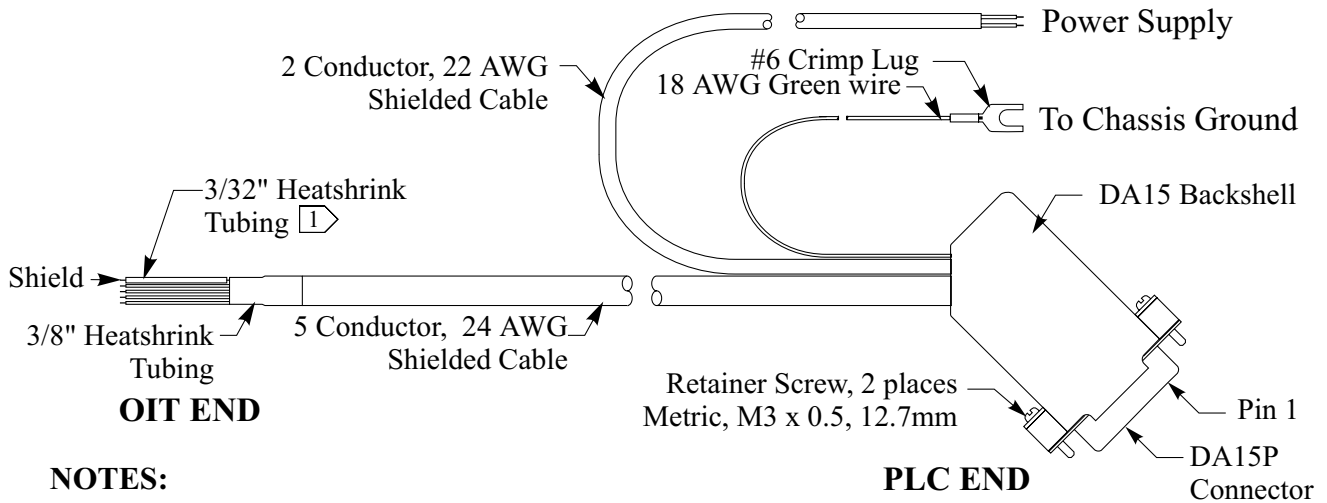

Controller Model: **Hitachi H Series**
 Maple OIT Model: **MAP460D, OIT3600B**
 Communication Type: **RS-232 with DA15 connector at PLC**

Use the wiring diagram and illustration to assemble a communication cable for use with a Hitachi H Series PLC.



NOTES:

- 1 Install heatshrink on shield (bare wire) to avoid shorting to components.
- 2 Twist together 18 AWG green wire and shield wire. Solder wires and insulate with heatshrink tubing to avoid shorting.

