



Controller Model: **Modicon Micro or Momentum**

Maple OIT Model: **MAP460D, OIT3600B**

Communication Type: **RS-232 with RJ-45 at PLC**

Use the wiring diagram and illustration to assemble a communication cable for use with a Modicon Micro or Momentum PLC.

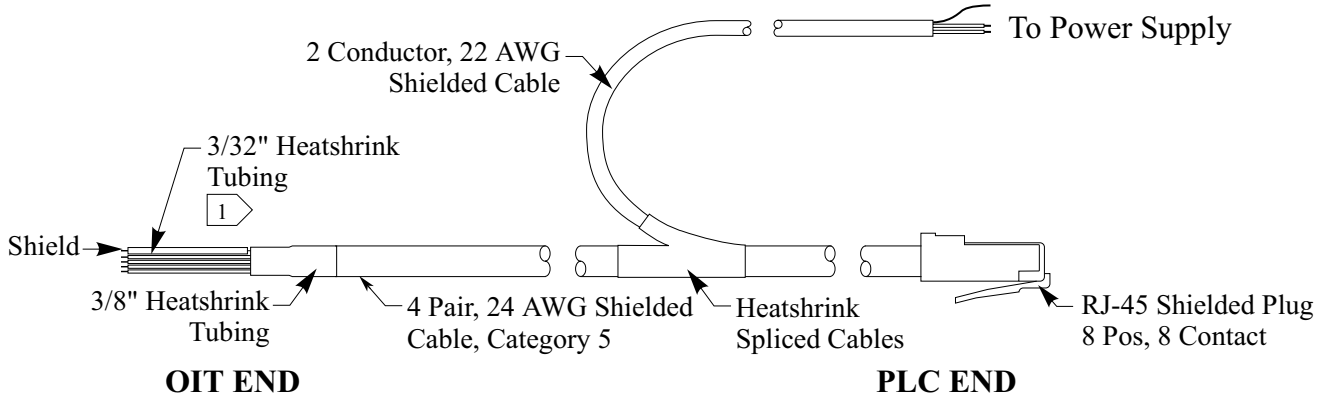

- 1 Install heatshrink on shield (bare wire) to avoid shorting to components.
- 2 Splice cables and shield. Heatshrink and seal connection.

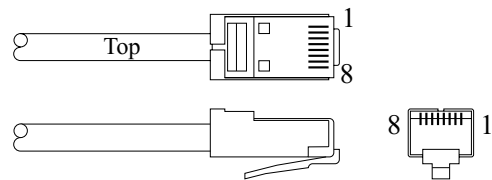
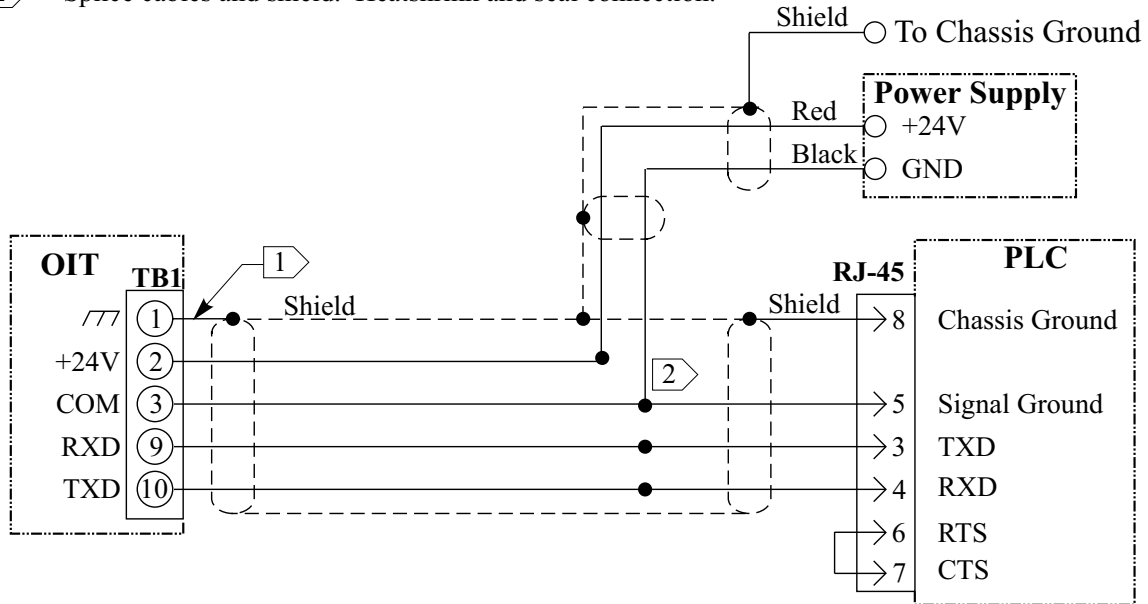

**Pin Configuration  
RJ-45 Plug**