



Controller Model: **Koyo DL205 (D2-250 CPU)**

Maple OIT Model: **MAP460D, OIT3600B**

Communication Type: **RS-232 with 15 pin SVGA connector at PLC**

Use the wiring diagram and illustration to assemble a communication cable for use with a Koyo DL205 PLC (D2-250 CPU, Port 2).

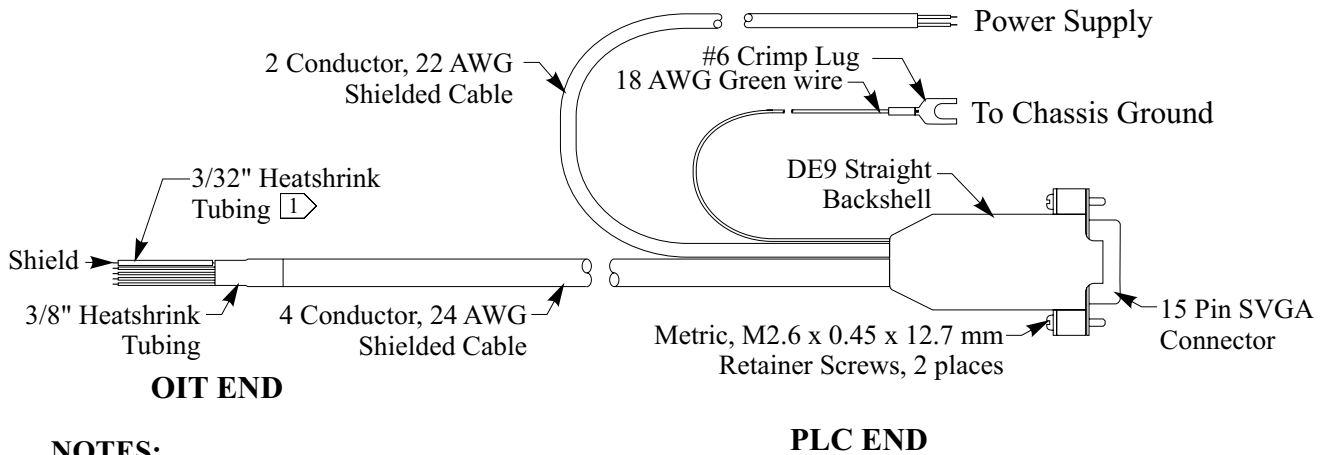

NOTES:

- 1 Install heatshrink on shield (bare wire) to avoid shorting to components.
- 2 Twist together 18 AWG green wire and shield wire. Solder wires and insulate with heatshrink tubing to avoid shorting.

