



Controller Model: **Koyo DL305 (D3-330 CPU, D3-350 CPU)**

Maple OIT Model: **OIT3100 and OIT4100 Series**

Communication Type: **RS-232 with DB25 connector at PLC**

Use the wiring diagram and illustration to assemble a communication cable for use with a Koyo DL305 PLC (D3-330 CPU with D3-232 DCU module or D3-350 CPU, Port 2).

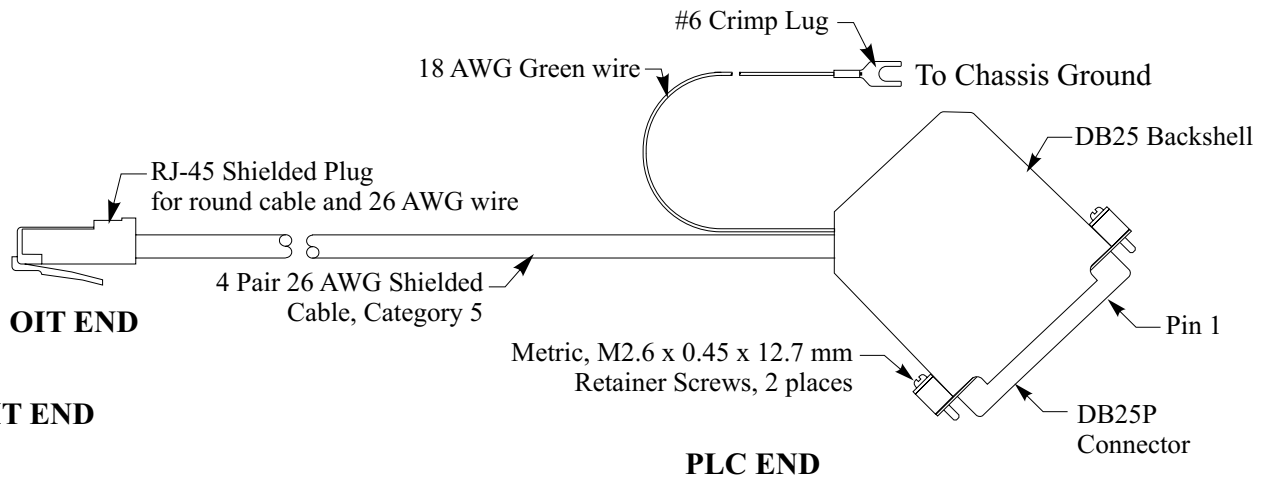

**NOTES:**

- 1 Twist together 18 AWG green wire and shield wire. Solder wires and insulate with heatshrink to avoid shorting.
- 2 Connect shield wire to the metal housing of the RJ-45 connector.

