



Controller Model: **Industrial Control Links ICL Series and SIXNET Controllers**

Maple OIT Model: **OIT3100 and OIT4100 Series**

Communication Type: **RS-232 with DE9 connector at Controller**

Use the wiring diagram and illustration to assemble a communication cable for use with an Industrial Control Links ICL Series controller or with a SIXNET SIXTRAK Gateways or VersaTrak RTUs controller.

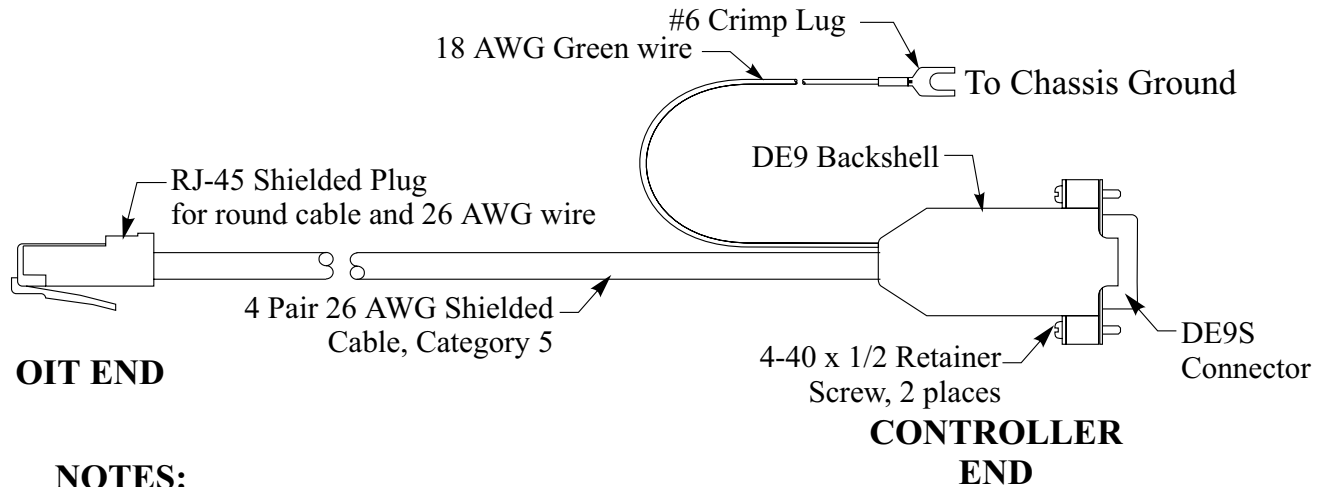

NOTES:

- 1 ➤ Twist together 18 AWG green wire and shield wire. Solder wires and insulate with heatshrink to avoid shorting.
- 2 ➤ Connect shield wire to the metal housing of the RJ-45 connector.

