



Controller Model: **Electric Motor Systems G5,  
Saftronics VG5 Modbus,  
Yaskawa Magnetek GPD Modbus**

Maple OIT Model: **OIT3100 and OIT4100 Series**

Communication Type: **RS-232 with 4 Pin XA connector at Controller**

Use the wiring diagram and illustration to assemble a communication cable for use with an Electric Motor Systems G5, Saftronics VG5 Modbus controller, or Yaskawa GPD Drive.

**NOTE:** For information on the XA connector call JST Corporation at 800-947-1110 (housing # XAP-04V-1, contact # SXA-001T-P0.6).

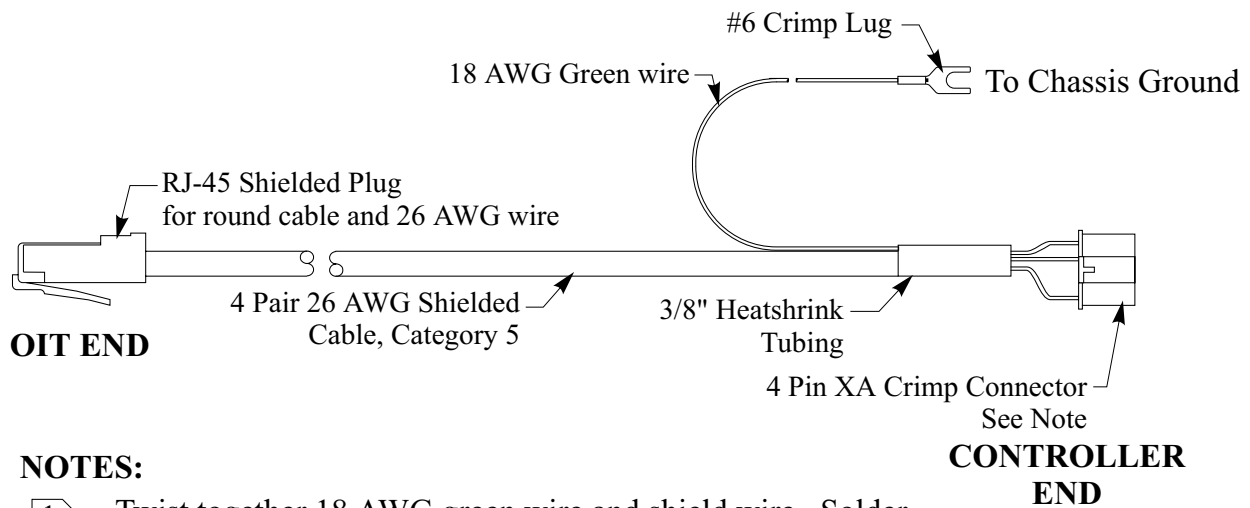

**NOTES:**

- 1 ➤ Twist together 18 AWG green wire and shield wire. Solder wires and insulate with heatshrink to avoid shorting.
- 2 ➤ Connect shield wire to the metal housing of the RJ-45 connector.

