

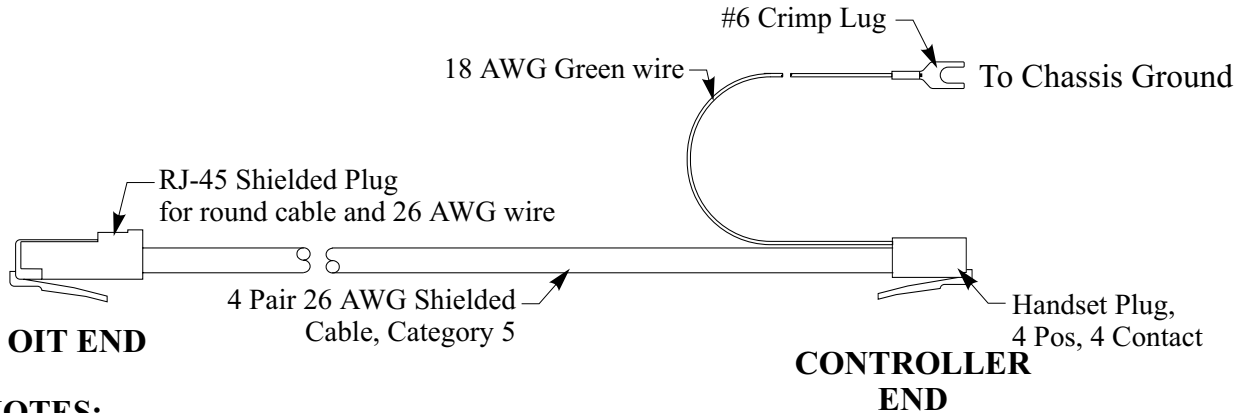

Controller Model: **Motorola RTU**  
 Maple OIT Model: **OIT3100 and OIT4100 Series**  
 Communication Type: **RS-485 with Handset connector at Controller**

Use the wiring diagram and illustration to assemble a communication cable for use with a Motorola RTU MOSCAD or MOSCAD Lite controller.



**NOTES:**

- 1 ▷ Twist together 18 AWG green wire and shield wire. Solder wires and insulate with heatshrink to avoid shorting.
- 2 ▷ Connect shield wire to the metal housing of the RJ-45 connector.
- 3 ▷ Numbering for the PLC end is shown with both conventional Handset numbering and with Motorola numbering. Motorola numbering is reversed from conventional.

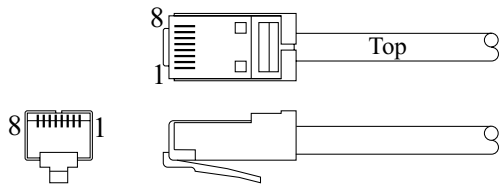
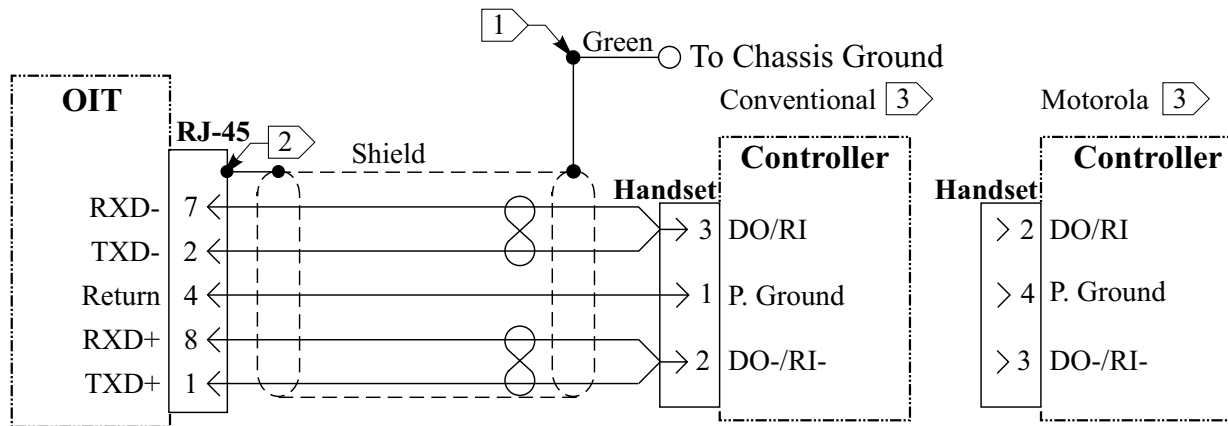

Pin Configuration  
RJ-45 Plug

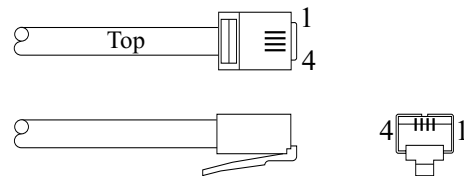

Conventional  
Pin Configuration  
Handset Plug