



Controller Model: **Aromat FP3**

Maple OIT Model: **OIT3100 and OIT4100 Series**

Communication Type: **RS-485/RS-422 with DA15 connector at PLC**

Use the wiring diagram and illustration to assemble a communication cable for use with an Aromat FP3 PLC.

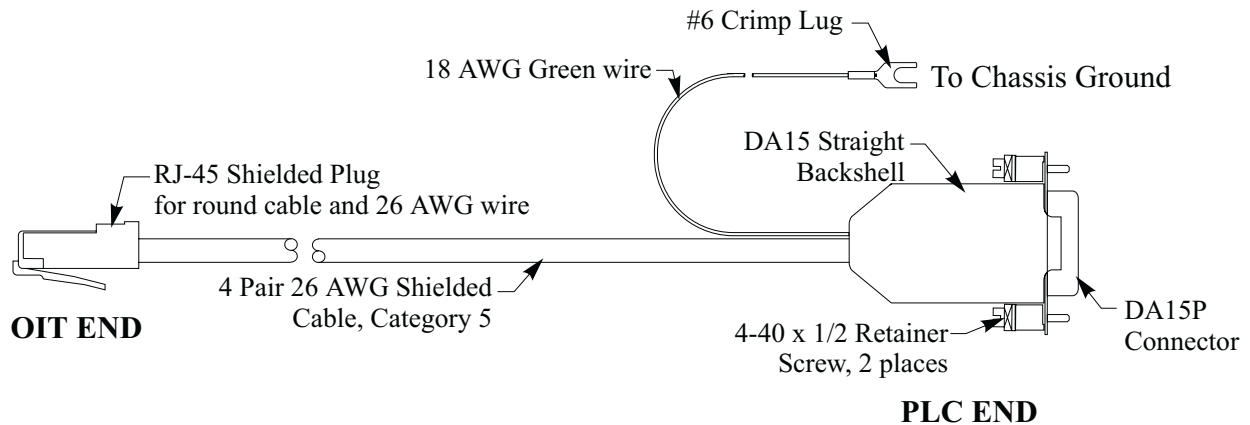

NOTES:

- 1 Twisting together 18 AWG green wire and shield wire. Solder wires and insulate with heatshrink to avoid shorting.
- 2 Connecting shield wire to the metal housing of the RJ-45 connector.

