



Controller Model: **Siemens S7-300 (HMI or PC Adapter) and Baldor Motion Controller**

Maple OIT Model: **Silver Series HMI504T**

Communication Type: **RS-232 with DE9 connector at PLC**

Use the wiring diagram and illustration to assemble a communication cable for use with a Siemens S7-300 PLC connecting to a Siemens HMI Adapter (Siemens P/N 6ES7-972-9CA11-0XA0) or PC Adapter (Siemens P/N 6ES7-972-9CA23-0XA0) or for use with a Baldor Motion Controller.

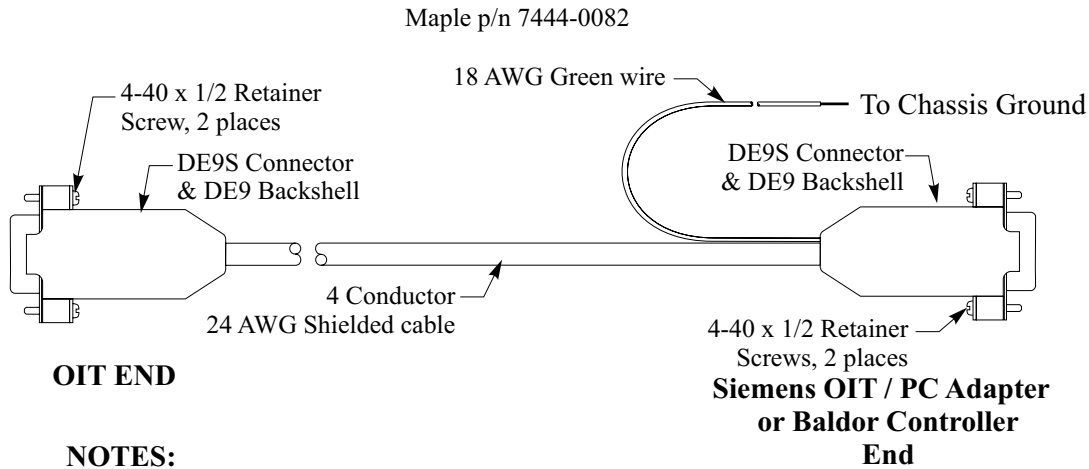

NOTES:

- 1 Twist together 18 AWG green wire and shield wire. Solder wires and insulate with heatshrink to avoid shorting.

