

CABLE ASSEMBLY INSTRUCTION

Maple Model(s)

HMI5000 Series (COM1)
HMI600 Series

PLC or Controller

Aromat FP0, FP2, FPM

Communication Type

RS-232 with Mini DIN 5
at PLC



Summary

Use the wiring diagram and illustration to assemble a communication cable for use with an Aromat FP0, FP2, or FPM PLC.

Drawing and Schematic

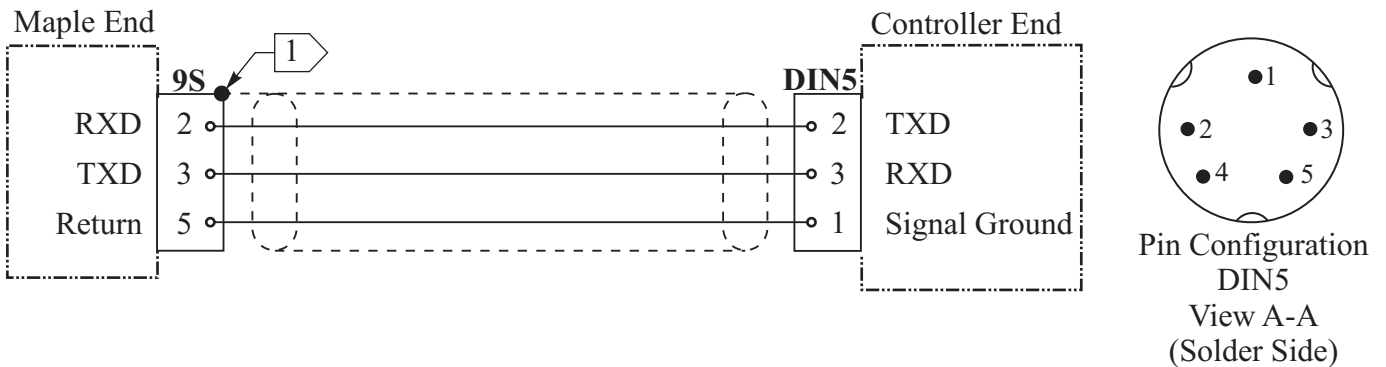
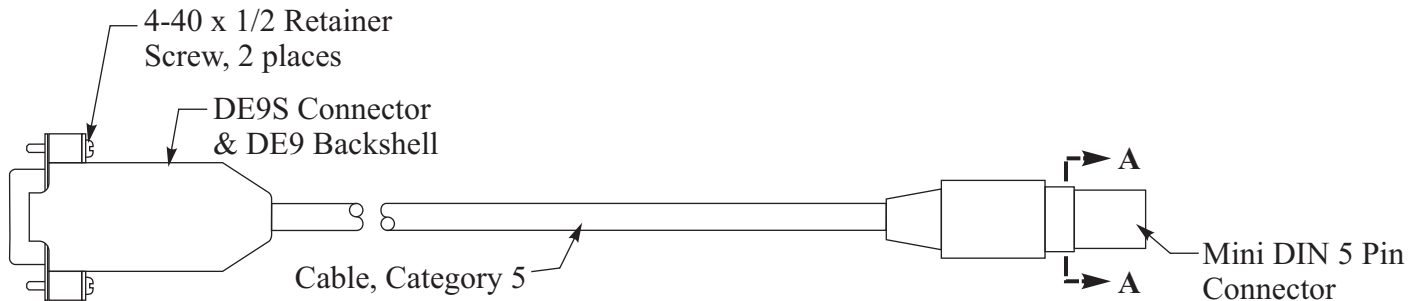

Notes

- 1 Shield wire must be terminated to connector metal shell.