



Controller Model: **Industrial Control Links ICL Series, SIXNET SIXTRAK Gateway and VersaTrak RTU Controllers**

Maple OIT Model: **Ivory Series (COM1), Gold Series, Silver Series Plus (COM1)**

Communication Type: **RS-232 with DE9 connector at Controller**

Use the wiring diagram and illustration to assemble a communication cable for use with an Industrial Control Links ICL Series controller, and SIXNET SIXTRAK Gateway and VersaTrak RTU controllers.

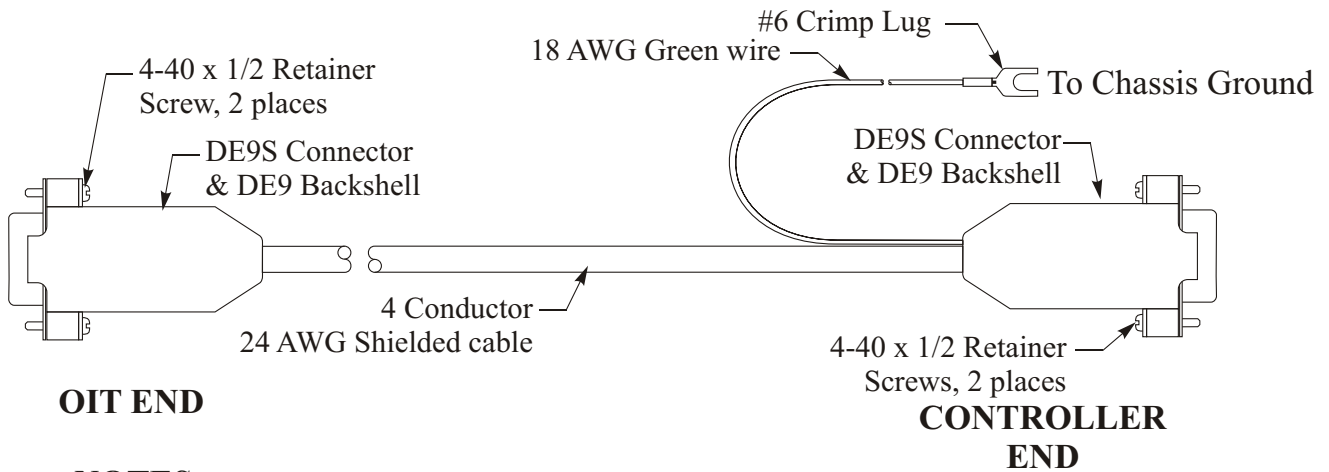

**NOTES:**

- 1) Shield wire must be terminated to connector shell.
- 2) Twist together 18 AWG green wire and shield wire. Solder wires and insulate with heatshrink to avoid shorting.

