



Extended Temperature
 316 Stainless Steel
 Class1Div2
 High Brightness

15.0" ~ 19.0" Hazardous Locations

Fanless Panel PC with Intel® Celeron® N2930 CPU

- CSA C1D2, C2D2, C3, ATEX / IECEx Zone 2, Zone 22 Certified for Use in Harsh Environments
- High Brightness Sunlight Readable (1000 Nits) Optically Bonded TFT LCD
- Extended Operating Temperature (-20~60°C)
- 316 Stainless Steel Chassis with IP66 Rating on All Sides
- Microsoft Windows® 10 IoT 2019 Operating System

System	CPU	Intel® Celeron™ N2930 Quad-Core 1.83GHz Processor	
	System Chipset	SoC	
	System Memory	Onboard DDR3L 8 GB 1333 MHz	
I/O Ports	Connector Type	M12, with waterproof cover and tether chain*	
	USB	1 x M12 8-pin for 2 x USB 2.0 type A*	
	Serial	1 x M12 8-pin for RS-232/422/485, DE-9, COM1 (default RS-232)*	
	Audio	N/A	
	Graphics	1 x M12 12-pin for VGA*	
	LAN	2 x M12 8-pin for RJ-45*	
	Power	1 x M12 3-pin for DC power input (leads)*	
	Remote Power Switch	N/A	
Touch Screen	Type	Projected Capacitive	
	Interface	USB (Internal)	
	Light Transmission	90+%	
Display	Display Type	15.0" XGA TFT LCD	19.0" SXGA TFT LCD
	Max. Resolution	1024 x 768	1280 x 1024
	Max. Color	262K	16.7M
	Luminance (cd/m²)	1000	1000
	View Angle (H°/V°)	160/140	170/160
	Contrast Ratio	800:1	1000:1
	Backlight Lifetime (hrs)	50,000+	70,000+
Storage	Internal Storage Device	1 x 128 GB 2.5" SATA III, MLC SSD 1 x 64 GB mSATA MLC SSD	
	SD Card Slot	N/A	
Electrical	Input Voltage	9-36 VDC	9-36 VDC
	Input Current	1.12-4.48 A	1.83-7.31 A
	Input Power (max.)	40.3 W	65.8 W
Mechanical	Dimensions (W x H x D)	15.71 x 12.76 x 2.76 inches [399 x 324 x 70 mm]	18.50 x 15.30 x 2.95 inches [470 x 388.6 x 75 mm]
	Net Weight	Approx. 21.61 lbs [9.8 kg]	Approx. 27.12 lbs [12.3 kg]
	Mounting	VESA 100 x 100 mm	
	Construction	316 Stainless Steel Chassis	
Environmental	Operating Temperature	-4~140°F [-20~60°C]	
	Storage Temperature	-22~158°F [-30~70°C]	
	Relative Humidity	10 to 95% @ 40°C, non-condensing	
	Rating	IP66	
	Certifications	ATEX / IECEx Zone 2 Ex ec ic IIC T4 Gc ATEX / IECEx Zone 22 Ex tc IIIC T135°C Dc Class I Division 2 Group A, B, C, D, T4 Class II Division 2 Group F, G, T135°C Class III ANSI/ISA 12.12-01-2013 CSA Std. C22 No213-1987, C22.2 No.61010 CE / FCC Class A / RoHS	
Operating System	Microsoft Windows	Microsoft Windows® 10 IoT Enterprise 2019 LTSC 64-bit (PKEA)	
Notes	* AEx units come provided with the following I/O cables; M12 waterproof connectors for PC side, other end of I/O cable is corresponding specified connector type:		
	<ul style="list-style-type: none"> • 1x DE-9 • 1x VGA • 1x USB 2.0 Type A • 2x RJ-45 I/O cable length: 10', Power cable length: 15' Specifications subject to change without notice.		

AEx-815PH



TOP VIEW

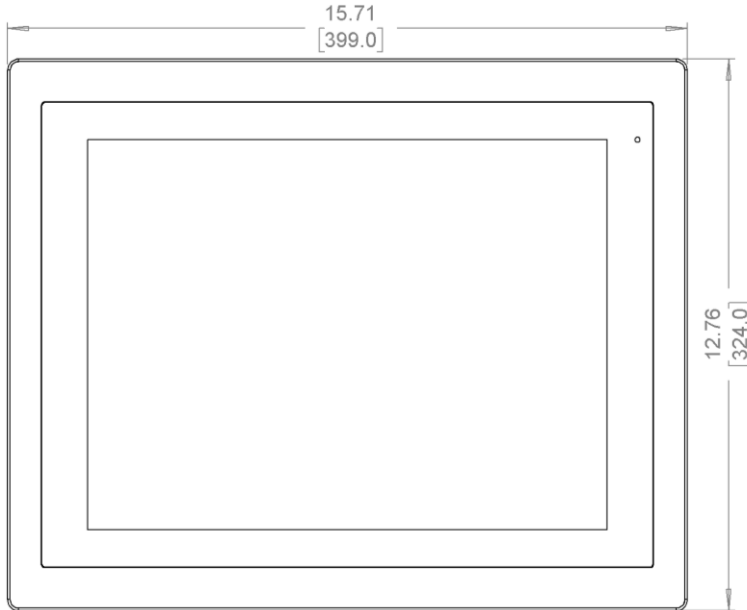

FRONT VIEW

DIMENSIONS ARE IN INCHES [MM]

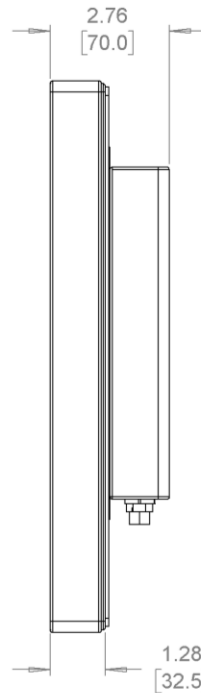

SIDE VIEW

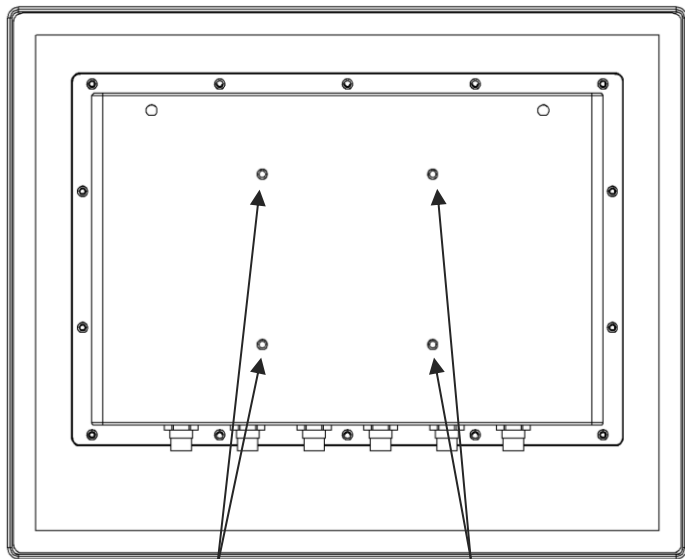

REAR VIEW

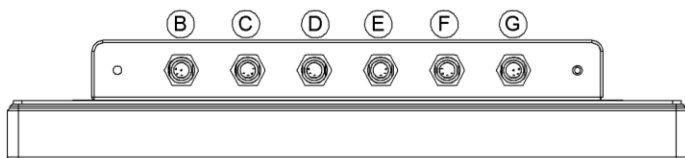

BOTTOM VIEW

- A VESA 100 x 100 mm Screw Holes
- B M12 VDC Power Connector
- C M12 LAN Connector
- D M12 USB 2.0 Connector
- E M12 COM1 Connector
- F M12 LAN Connector
- G M12 VGA Connector

AEx-819PH

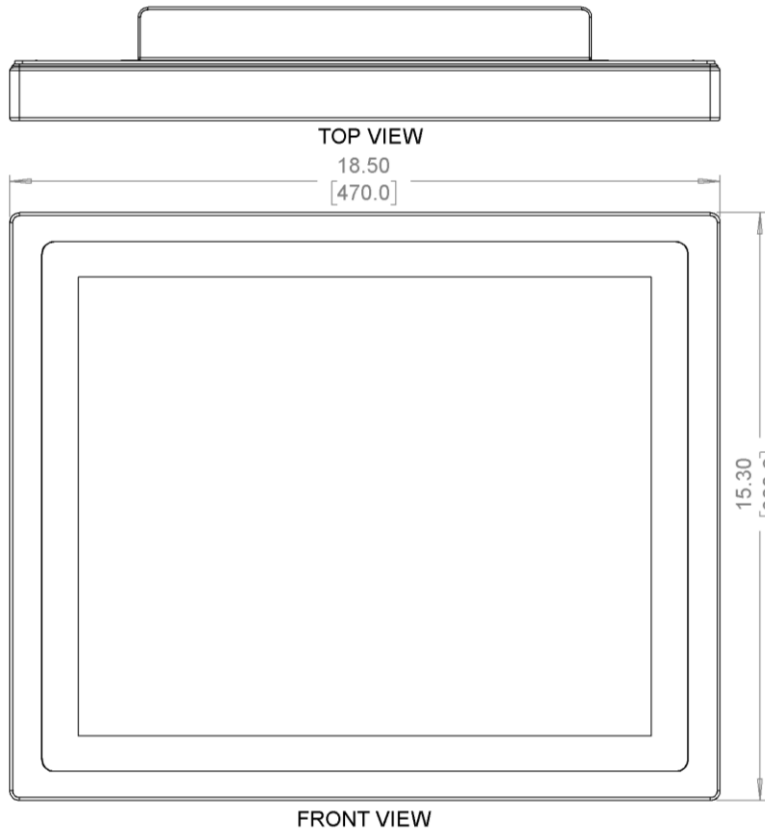

DIMENSIONS ARE IN INCHES [MM]

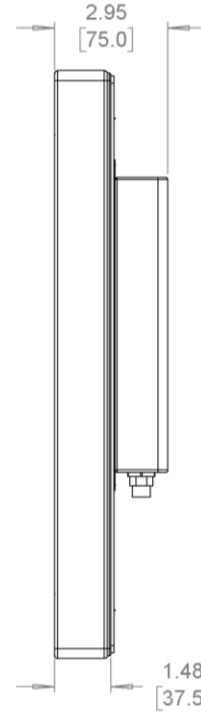

SIDE VIEW

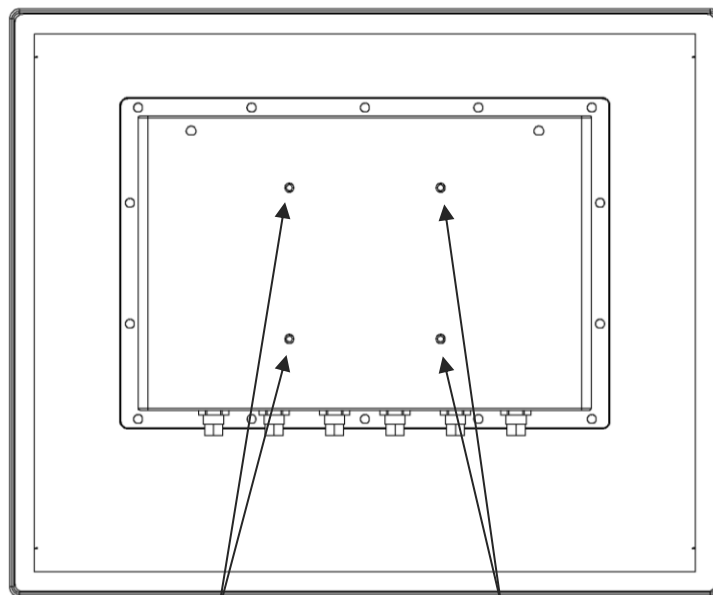

A A



BOTTOM VIEW

- A VESA 100 x 100 mm Screw Holes
- B M12 VDC Power Connector
- C M12 LAN Connector
- D M12 USB 2.0 Connector
- E M12 COM1 Connector
- F M12 LAN Connector
- G M12 VGA Connector